

POLYGLASS ROOFING SYSTEM DETAIL

6" WIDE (MIN.) BASE COAT, POLYESTER FABRIC AND BASE FOUNDATION COAT COMPONENTS OVER EXISTING JOINT

POLYGLASS ROOF COATING SYSTEM: BASE COAT, POLYESTER FABRIC, BASE COAT AND SURFACE FINISH COAT

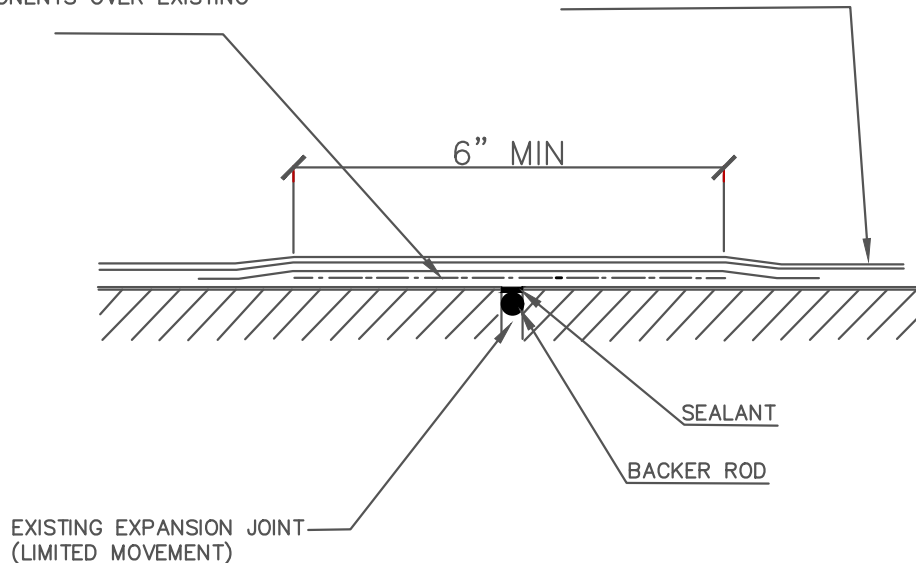

DETAIL KEYNOTES

- SURFACE COAT                      POLYGLASS ELASTOMERIC ROOF COATINGS.
- BASE COAT                            POLYGLASS ELASTOMERIC ROOF COATINGS.
- FLASHING COMPOUND            POLYGLASS FLASHING COMPOUND AS REQUIRED. APPLY AT 1/8" THICK AND USE WITH POLYESTER REINFORCEMENT.
- POLYESTER                            POLYGLASS REINFORCING POLYESTER.
- SURFACE PREPARATION            ALL SURFACES SHALL BE CLEAN, DRY AND FREE OF ANY DIRT, DUST, GRAVEL, OIL, SURFACE CHEMICALS OR OTHER CONTAMINANTS THAT MAY INTERFERE WITH OPTIMUM ADHESION. POLYGLASS RECOMMENDS AN ADHESION TEST PRIOR TO COATING APPLICATION. IF ADHESION TEST FAILS, ADDITIONAL CLEANING AND/OR PRIMING MAY BE REQUIRED.

ROOF EXPANSION JOINT DETAIL

NUMBER:

PG-REJ-008

DATE:

NOVEMBER 2016



www.polyglass.com